

Printer/Scanner Unit
(Machine Code: B580)

IEEE1394 Board
(Machine Code: B581)

USB
(Machine Code: B596)

IEEE802.11B (Wireless LAN)
(Machine Code: B582)

Media Link Board
(Machine Code: B609)

1. CONTROLLER BOARD SPECIFICATIONS

CPU:	AMD 800 MHz
BIOS ROM:	1 MB (512 K x 2)
OS Copy Flash ROM:	16 MB
NVRAM:	128 KB
SDRAM:	128 MB
DDR-SDRAM:	Slot #1 (Standard): BASIC 128 MB Slot #2 (Option): 256 MB
PCI Option:	4 Slots (B1 to B4)
SD Card:	3 Slots (C1 to C3)
RAPI Option:	2 Slots (A1, A2)
Power Supply Voltage:	DC 5VE \pm 3% DC 12VE \pm 5%

2. ETHERNET BOARD (B580/B594)

The Ethernet board is provided as a standard feature of this machine.

Function Blocks	Description
PHY (Physical Layer Device)	Completely standardized physical layer device for the functions of each device in the network.
EEPROM	Stores the MAC address.

The physical layer device, the lowest layer of the OSI reference model, refers to the physical components of the network: cables, connectors, and so on. OSI, the *Operating Standard Interface*, is a framework upon which networking standards are arranged. It is commonly diagrammed as a layered cake.

2.1 ETHERNET BOARD OPERATION

The NIB is a standard IEEE802.3u type which implements 10/100Mbps auto negotiation. System initialization sets the network for 10Mbps/100Mbps.

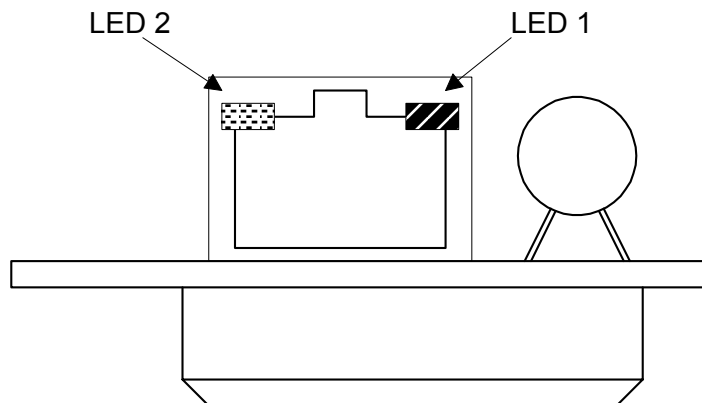

B580D003.WMF

LED 1 (Green)	Indicates the link status: ON Link Safe OFF Link Fail
LED 2 (Orange)	Indicates the operation mode: ON 100 Mbps mode OFF 10 Mbps mode

3. IEEE1394 BOARD (FIREWIRE) (B581)

3.1 OVERVIEW

An IEEE1394 interface board is available as an option for this machine to provide high speed connectivity through what is commonly called Firewire or i.LINK (Sony). Some important advantages of Firewire are:

- High speed data transmission at 400 Mbps.
- Easier connectivity (many devices can be connected without a host).
- Devices in a computer can be connected to external devices on a shared bus.

IEEE1394 supports two printing methods: 1) SCSI Print, and 2) IP Over 1394. IP Over 1394 supports printing by setting an IP address, and SCSI supports printing without an IP address.

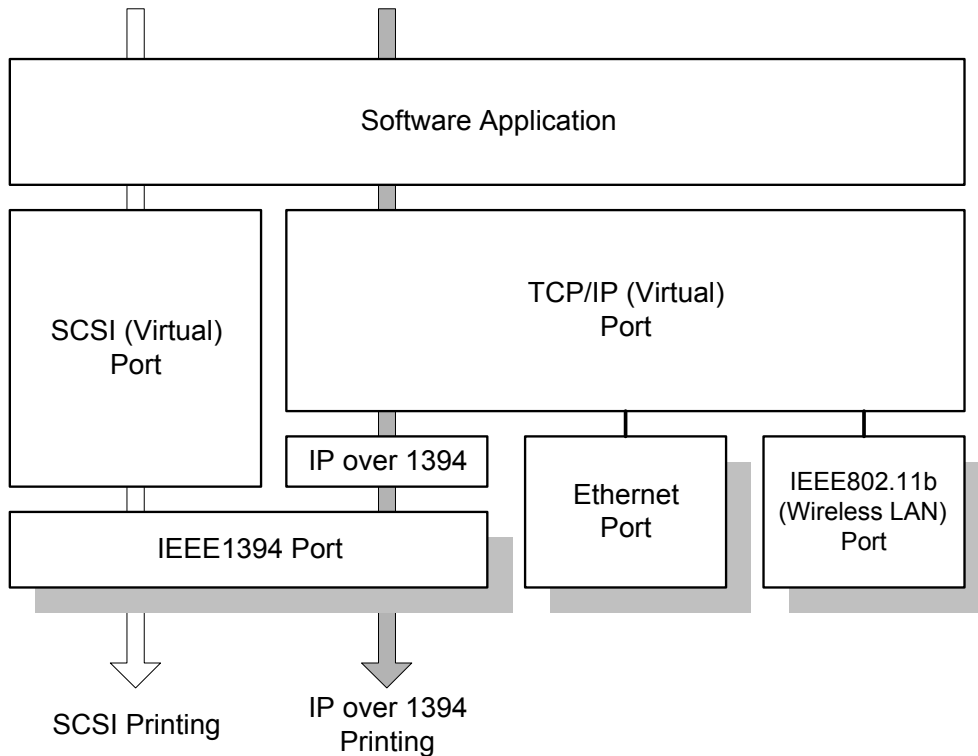

B580D902.WMF

NOTE: 1) Windows Me and Windows XP support IP over 1394.
2) Windows XP and 2000 support IEEE1394 SCSI printing.

When the host computer powers up, it queries all the devices connected to the bus and assigns each one an address, a process called enumeration. Here are some general features of Firewire:

- Firewire is Plug-and-Play.
- Firewire devices are hot pluggable (they can be plugged while the system is operating).
- Firewire uses 64-bit fixed addressing, based on the IEEE 1212 standard. There are three parts to each packet of information sent by a device over FireWire:
 - 10-bit Bus ID. Used to determine the Firewire bus where the data came from.
 - 6-bit Physical ID. Used to identify the device that sent the data.
 - 48-bit Storage Area. Capable of addressing 256 terabytes of information for each node
- The Bus ID and Physical ID comprise the 16-bit Node ID. 64,000 nodes are allowed on each system.
- Up to 16 hops are allowed (4.5 m/hop) for a total of 72 meters devices are daisy-chained.
- Firewire allows its devices to draw power from the Firewire connection. Two power connectors in the cable can supply power (8 to 40 V, 1.5 amp max.)
- An important element of Firewire is its support of isochronous devices. When isochronous devices are in the isochronous mode, data streams between the device and the host in real time with guaranteed bandwidth and no error correction. Essentially, this means that a device like a digital camcorder can request that the host computer allocate enough bandwidth for the camcorder to send uncompressed video in real time to the computer. The camera can send data via the Firewire connection in a steady flow to the computer without anything disrupting the process. This is one of the main reasons why 1394 has been widely adopted by the consumer electronics industry.

4. USB (B596)

4.1 SPECIFICATIONS

USB connectivity is provided as an option for this machine.

Interface	USB 1.1, USB 2.0
Data rates	480 Mbps (high speed), 12 Mbps (full speed), 1.5 Mbps (low speed)
	High speed mode is only supported by USB 2.0.

4.2 USB 1.1/2.0

USB (Universal Serial Bus) offers simple connectivity for computers, printers, keyboards, and other peripherals. In a USB environment, terminators, device IDs (like SCSI), and DIP switch settings are not necessary.

USB 1.1 provides the following features:

- Plug & Play. As soon as a new device is connected via USB, the operating system recognizes it, and the appropriate driver is installed for it automatically if the driver is available. If the driver is not available, a message prompts the user for the driver disk for immediate installation.
- Hot swapping (cables can be connected and disconnected while the computer and other devices are switched on)
- No terminator or device ID required
- Data rates of 12 Mbps (full speed), and 1.5 Mbps (low speed)
- Common connectors for different devices
- Bi-directional data communication between device and host computer via a 4-byte header and DEVICE ID.

USB 2.0 is an evolution of the USB 1.1 specification. It uses the same cables, connectors, and software interfaces so the user will see no change. It provides an easy-to-use connection to a wide range of products with a maximum data rate of 480Mbps (high speed).

Up to 127 devices can be connected and 6 cascade connections are allowed. Power is supplied from the computer and the maximum cable length is 5 m.

4.3 USB CONNECTORS

USB is a serial protocol and a physical link, which transmits all data on a single pair of wires. Another pair provides power to downstream peripherals. The USB standard specifies two types of connectors, type “A” connectors for upstream connection to the host system, and type “B” connectors for downstream connection to the USB device.

Type “A” connector

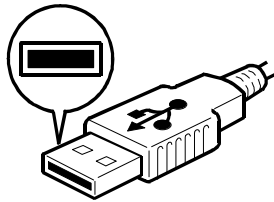

B580D904.WMF

Type “A” connector

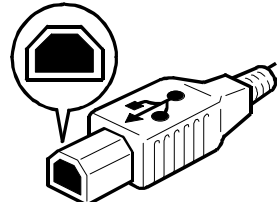

B580D905.WMF

4.4 REMARKS ABOUT USB

- The machine does not print reports specifically for USB.
- Only one host computer is allowed for the USB connection.
- After starting a job using USB, do not switch the printer off until the job has been completed. When a user cancels a print job, if data transmitted to the printer has not been printed at the time of cancellation, the job will continue to print up to the page where the print job was cancelled
- When the controller board is replaced, the host computer will recognize the machine as a different device.

4.4.1 RELATED SP MODE

“USB Settings” in the printer engine service mode. Data rates can be adjusted to full speed fixed (12 Mbps). This switch may be used for troubleshooting if there is a data transfer error using the high speed mode (480Mbps).

Data rates can also be adjusted using the UP mode “USB Setting” in the Host Interface in the System menu. This mode can be accessed only when the “Enter”, “Escape”, then “Menu” keys are pressed to enter the UP mode.

5. IEEE802.11B (WIRELESS LAN) (B582)

5.1 WIRELESS LAN SPECIFICATIONS

The IEEE 802.11b wireless LAN interface card is available as an option for this machine.

A wireless LAN is a flexible data communication system used to extend or replace a wired LAN. Wireless LAN employs radio frequency technology to transmit and receive data over the air and minimize the need for wired connections.

- With wireless LANs, users can access information on a network without looking for a place to plug into the network.
- Network managers can set up or expand networks without installing or moving wires.
- Most wireless LANs can be integrated into existing wired networks. Once installed, the network treats wireless nodes like any other physically wired network component.
- Flexibility and mobility make wireless LANs both effective extensions of and attractive alternatives to wired networks.

Standard applied:	IEEE802.11b	
Data transmission rates:	Speed	Distance
	11 Mbps	140 m (153 yd.)
	5.5 Mbps	200 m (219 yd.)
	2 Mbps	270 m (295 yd.)
	1 Mbps	400 m (437 yd.)
Network protocols:	TCP/IP, Apple Talk, NetBEUI, IPX/SPX	
Bandwidth:	2.4GHz (divided over 14 channels, 2400 to 2497 MHz for each channel)	

NOTE: The wireless LAN cannot be active at the same time as the Ethernet LAN. The following user tool setting determines which LAN is active: System Settings – Interface Settings – Network - LAN Type.

LED Indicators

LED	Description	On	Off
LED1 (Green)	Link status	Link success	Link failure
LED2 (Orange)	Power distribution	Power on	Power off

5.2 WIRELESS LAN TRANSMISSION MODES

Wireless communication has two modes: 1) ad hoc mode, and 2) infrastructure mode.

5.2.1 AD HOC MODE

The ad hoc mode allows communication between each device (station) in a simple peer-to-peer network. In this mode, all devices must use the same channel to communicate. In this machine, the default transmission mode is ad hoc mode and the default channel is 11. First, set up the machine in ad hoc mode and program the necessary settings, even if the machine will be used in the infrastructure mode.

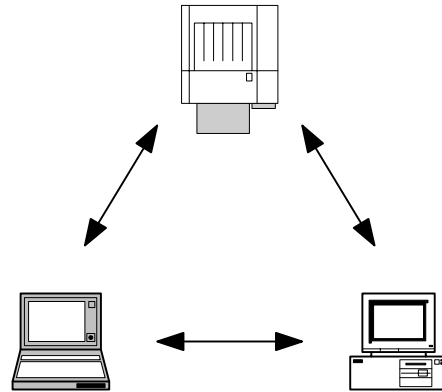

B580D907.WMF

To switch between ad hoc and infrastructure modes, use the following user tool: Host Interface Menu - IEEE802.11b - Comm Mode

5.2.2 INFRASTRUCTURE MODE

The infrastructure mode allows communication between each computer and the printer via an access point equipped with an antenna and wired into the network. This arrangement is used in more complex topologies. The wireless LAN client must use the same SSID (Service Set ID) as the access point in order to communicate.

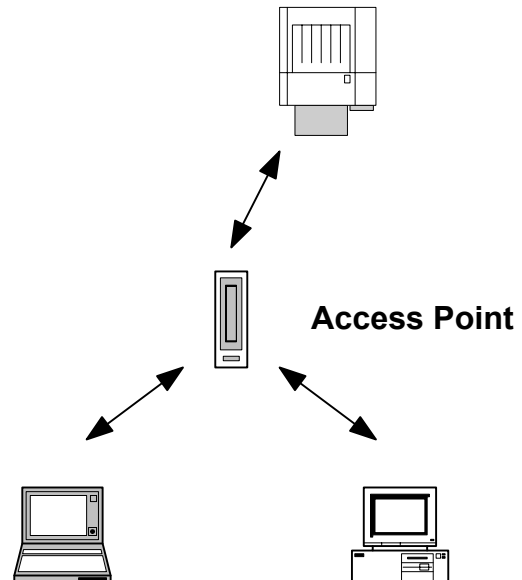

B580D908.WMF

5.3 WIRELESS LAN SECURITY FEATURES

SSID (Service Set ID)

The SSID is used by the access point to recognize the client and allow access to the network. Only clients that share the same SSID with the access point can access the network.

NOTE: 1) If the SSID is not set, clients connect to the nearest access point.
2) The SSID can be set using the web status monitor or telnet.

5.3.1 USING THE SSID IN AD HOC MODE

When the SSID is used in ad hoc mode and nothing is set, the machine automatically uses "ASSID" as the SSID. In such a case, "ASSID" must also be set at the client.

NOTE: SSID in ad hoc mode is sometimes called "Network Name."

Some devices automatically change from ad hoc mode to infrastructure mode when the same SSID is used in ad hoc mode and infrastructure mode. In such a case, to use the device in ad hoc mode, use a specified SSID in infrastructure mode and use "ASSID" in the ad hoc mode.

WEP (Wired Equivalent Privacy)

WEP is a coding system designed to protect wireless data transmission. In order to unlock encoded data, the same WEP key is required on the receiving side. There are 64 bit and 128 bit WEP keys. However, this machine supports only 64 bit WEP.

NOTE: The WEP key can be set using the Web Status Monitor or Telnet.

MAC Address

When the infrastructure mode is used, access to the network can also be limited at the access points using the MAC address. This setting may not be available with some types of access points.

5.4 WIRELESS LAN TROUBLESHOOTING NOTES

Communication Status

Wireless LAN communication status can be checked with the UP mode “W.LAN Signal” in the Maintenance menu. This can also be checked using the Web Status Monitor or Telnet.

The status is described on a simple number scale.

Status Display	Communication Status
Good	76 ~ 100
Fair	41 ~ 75
Poor	21 ~ 40
Unavailable	0 ~ 20

NOTE: Communication status can be measured only when the infrastructure mode is being used.

5.4.2 CHANNEL SETTINGS

If a communication error occurs because of electrical noise, interference with other electrical devices, etc., you may have to change the channel settings.

To avoid interference with neighboring channels, it is recommended to change by 3 channels. For example, if there are problems using channel 11 (default), try using channel 8.

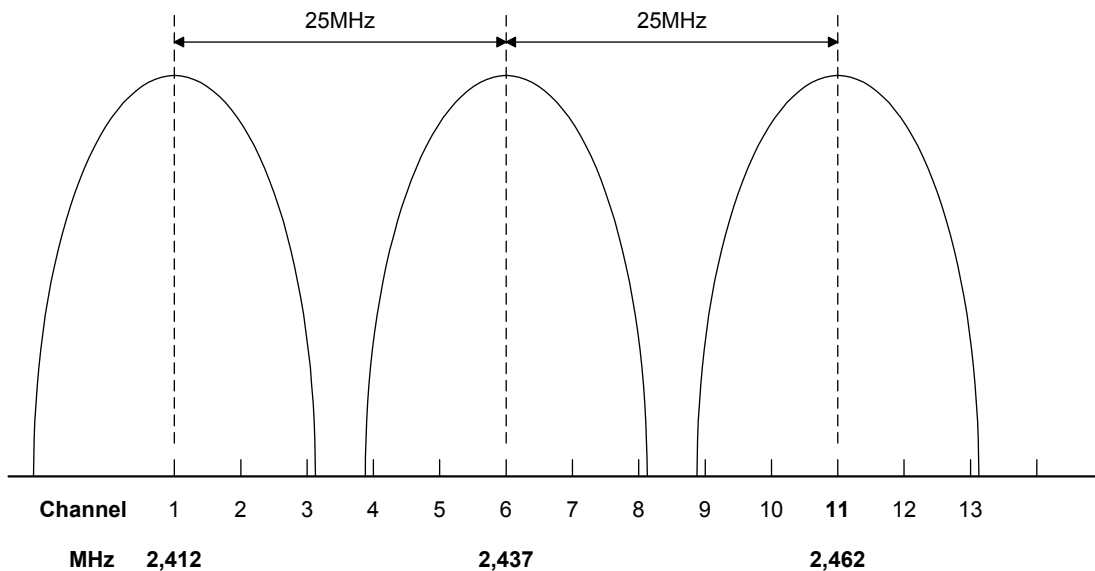

B580D901.WMF

5.4.3 TROUBLESHOOTING PROCEDURE

If there are problems using the wireless LAN, check the following.

- 1) Check the LED indicator on the wireless LAN card.
- 2) Check if "IEEE802.11b" is selected in the following user tool:
System Setting> Interface Setting> IEEE 801.11b

NOTE: The "IEEE 801.11b tab is available only after the IEEE 801.11b card has been installed.

- 3) Check if the channel settings are correct.
- 4) Check if the SSID and WEP are correctly set.

If infrastructure mode is being used,

- 1) Check if the MAC address is properly set.
- 2) Check the communication status.

If the communication status is poor, bring the machine closer to the access point, or check for any obstructions between the machine and the access point.

If the problem cannot be solved, try changing the channel setting.

5.5 IEEE 802.11B SPECIFICATIONS

Standard applied	IEEE802.11b	
Data transmission rates	Speed	Distance
	11 Mbps	140 m (153 yd.)
	5.5 Mbps	200 m (219 yd.)
	2 Mbps	270 m (295 yd.)
	1 Mbps	400 m (437 yd.)
Network protocols	TCP/IP, Apple Talk, NetBEUI, IPX/SPX	
Bandwidth	2.4GHz (divided over 14 channels, 2400 to 2497 MHz for each channel)	

6. MEDIA LINK BOARD (B609)

Copy and print jobs are stored on the document server (on the copier's hard disk) in a Ricoh proprietary file format.

In previous models (such as A-C2, R-C2), DeskTopBinder could retrieve copy and print jobs from the document server and convert them to TIFF. However, this software-based conversion was slow for many users.

So, for the B070/B071, this conversion has been made hardware-based, using the optional Media Link Board. Without the Media Link Board, copy and print jobs cannot be downloaded to a PC from the document server.

Two common target formats are provided for conversion to files that can be viewed on a computer: JPEG and TIFF.

NOTE: If the printer/scanner controller is not installed, the optional standalone NIB must be installed in the copier.

SP5847 (Net File Mag. Rate) is provided for use with this feature. For more details about these settings, see Section "5. Service Tables" in the main Service Manual.

NOTE: These SP commands are enabled for use only after the MLB has been installed. For details about installing the MLB, see Section "1. Installation" of the main Service Manual.

5847	002	Copy : Text	Changes the default settings of image data transferred externally by the Desk Top Binder page reference function via the MLB (Media Link Board).
5847	003	Copy: Others	
5847	005	Print: Binary	
5847	006	Print: Dither(1200 dpi)	Sets the default for dithered image size sent to the Document Server via the MLB (Media Link Board).
5847	021	NetFile Page Quality Default for JPEG	Sets the default for JPEG image quality of image files handled by Desk Top Binder sent via the MLB (Media Link Board).